

# Tributes to the Work of Victor Schauberger (Austria 1885-1958) with the Eyes of TRIZ

Wolfgang Sallaberger (Congelo, Austria )

## Abstract

Victor Schauberger was a forester in the Austrian mountains who observed and studied nature for a long time. He created the slogan "understand and copy nature" ( he used the word biotechnology around 1920). The main part of his work was about water. The work brings us to helix of flow and energy. Helixes may be found in our DNS, in flowing rivers, in the air and in many other things of our environment. Since water is contained in nearly everything, even in a burning flame(\*1), and it covers around 70% of the Earth, we will find helixes and their energy where we find water as well. This paper should open the door to that knowledge of Schauberger about water and its motion with the eyes of TRIZ (talking about water nearly means to talk about everything). Science/bionics lately found out that shark skin produces small helixes and helps to save energy. Schauberger discovered facts like those much earlier than others. He was a man of the future whose secret may only be recognized with the eyes of TRIZ. The underlined numbers you find in this paper do stand for the inventive Principles.

## 1. Introduction: How did I come up with Schauberger ?

I did not intend to be or do something like Schauberger, I did not exactly know what his work was about and I did not look for that.

After 9/11 I started thinking about an elevator or a rescue device for skyscrapers that can rescue people quickly and safely without help from outside.

I was working in the kitchen as a chef and I did not pursue this idea, since a title or another university degree is required for carrying out R&D in Austria.

### 1.1 Food



**Figure 1. Vegetable main dish**

Another project with convenience food started in 2004 and became very specific. The customers liked and ordered the product, but the distributors in Austria did not join in. Since this kind of food may not be created with conventional production lines, we are working on a prototype for this machine (after 4 years I found a company for this). The customers are still asking when it

will be available, but Austria is the wrong place for that. The food market is controlled by a handful of companies.

I created my first mass product which can be mass-produced with low costs. However, its appearance sets itself apart from normal mass products and allows an individual serving style.



**Figure 2. Polenta Tarte with Deere ragout stuffing**

If you have been at the ETRIA conference in Frankfurt 2007 you possibly ate one of these products.

The objective of inventing this kind of convenience food is to obtain a food which can be served in a short time, in different ways, with a maximum of nutrients and colours made of naturally grown plants (organic plants).

As a chef I worked in restaurants and hotels with 2 up to 240 employees where I learned that some problems exist in big and small companies.

This problem also occurred in my restaurant and the question was: how can I prepare a large amount of high-quality vegetable bouquets consisting of different vegetables by using different preparation and cooking processes? (During the service I do not have the resources to achieve this.)

In reality, when I worked in the kitchen, I learned that many people do not understand that different vegetables/plants require different spices and treatment methods.

So I asked myself what is the ideal solution for this:

1. Take it
2. Heat it
3. Serve it
4. Eat it



**Figure 3. Potato Salmon Tarte**

The solution is a product that needs no cooking skills in the final steps. Only during the manufacturing need skills and knowledge are needed. The preparation steps for the finishing of the product are indicated as symbols. This is important in kitchens where people from many nationalities work together.

This prior action and counter-action give the manufacturing and finishing process the maximum of your resources to create a high quality product that looks and tastes like freshly prepared. These dishes are not prepared by an overworked and stressed chef.

No matter if you prepare 1 or 1000 pieces for your guests, the appearance, all of them will have the same taste and the quality. I found out that many big hotels and restaurants are in search of such products. Mainly 4- and 5-star hotels and congress centres are interested in the product. Customers who take an interest in these products attach importance to



**Figure 4. Preparation manual**

quality and a good profitability.

The basis of the first mass product is a helix.

## 1.2 “Finding” the right detour at Etria Conference Frankfurt with TRIZ

In Frankfurt I got in contact with Mr. Nakagawa for the first time. After that I have seen a propeller Engine in the "TRIZ Home Page in Japan".

If you look at it, you will see a Engine which works with 2 helixes; later in this paper you find a draft from Schauberger showing this principle of the double Helix.

So I can say that the work of Mr. Nakagawa made me “cross the Rubicon” (= take a significant step) in order to get in contact with Schauberger’s work. (but still I did not realize that I am already into that.)

Between 2006 and 2007 the Shaman Elie Hien told me: “You should create something to rescue people from a flying/crashing plane” (he travels 50 times a year by plane)

First I asked myself how this might be possible, but after a while (3 months) and with the use TRIZ I created something specific - but only on paper.

I asked EADS and Boeing if they have a demand for such things because I knew that they construct planes for more than 900 passengers.

One answer was “if you think in a European way, you should first come to us”. In 2008 EADS asks at Austrian TRIZ society how such a plane could look like.

Somebody should visit EADS, even though they are not willing to pay anything – is this a European way of thinking ?

By accident I learned that one and some other things which I had created look similar to a thing Schauberger created when I saw a draft from Schauberger and therefore I took a closer look at his work.

It is not the same but looks like it could be the same.

I learned that the handling of new ideas in Europe did not change since Schauberger’s time.

Maybe you remember any ideas or plans which you had when you were a kid. If you think back to that time, you will notice that the understanding and the mind were very clear, but that no one would listen and therefore would give up on this and integrate ourselves into the normal working life. By using TRIZ some ideas have come back into my mind.

During the contact with Schauberger’s work I started to remember what I was thinking about when I was little child and little children think about a variety of things.

## 2. Victor Schauberger — His biography

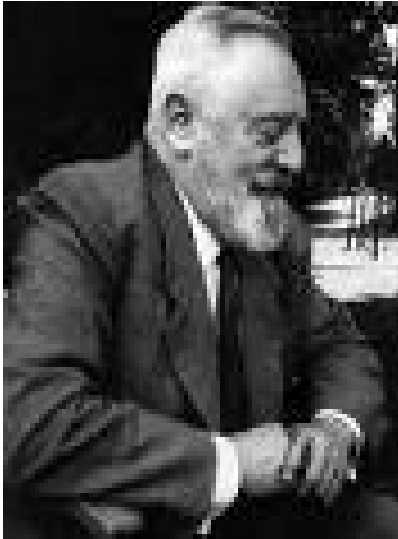

**Figure 5. Victor Schaubberger**

Born 1885 in Austria,

In his youth he lives in the Wood for 1 year after a confrontation with his Father.

1914: birth of his son Walter, 2 daughters followed later

1919: first job as forester,

1922: his first invention, a new construction of logging flumes which enabled to transport timber sticks at only 10% of the normal costs and timber which was heavier than water. Several constructions in different countries followed until 1928.

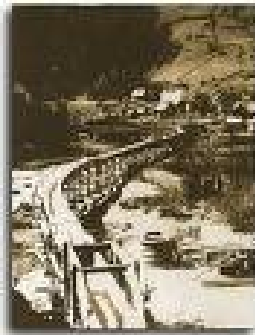

**Figure 6. Logging Flume\***



**Figure 7. Detail view of a Logging Flume**

1929: patent for a water turbine.

1932: patent for an apparatus to produce “precious water” which had healing effects and also included a

project for fuel production with this water. However, this project was finally stopped by the Medical Association.

1933: the book “Our Senseless Work” is written by Schaubberger. In this book he describes the problems which we have NOW with water, storms, agriculture and human health.

1934: discussion with Hitler; Schaubberger is not prepared to work for him

1935: patent for an air turbine for the transportation of gas,

1937: the Hot Cold Machine melts during a unauthorized test run by Siemens.

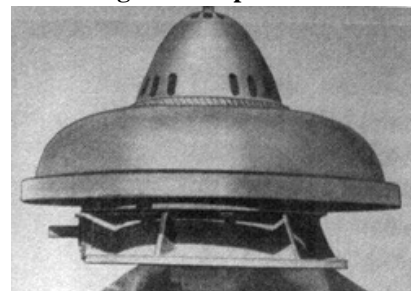

**Figure 8. Home generating plant**

1940: construction of the Repulsine,



**Figure 9. Repulsine**



**Figure 10. Repulsine**

In 1941 - after an intrigue committed by the engineering society the Repulsine was confiscated by the Nazis.

Schaubberger was put in the lunatic asylum for 3 days and under permanent observation by the SS followers of that time.

In 1943 he had to work on the Repulsine in the concentration camp Mauthausen; a Repulsine crashes down on the roof .

At the end of the Second World War he was under observation by the allies, all machines/models and documents were confiscated, main parts thereof were transported to the US and other parts to Russia.

Since Schauberger was deceived 12 times in his life, he started to make no or half plans and drawings in order to protect his work and keep it secret.

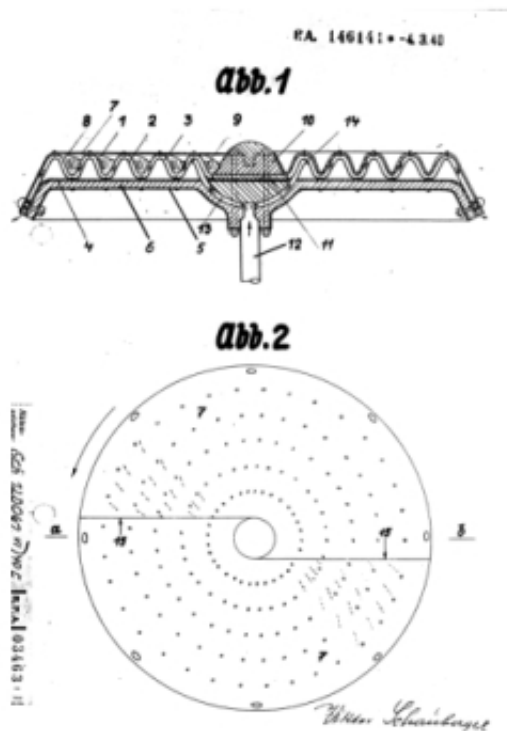

**Figure 11. draft of Repulsine inside**

In a letter he wrote “they give me only the broken models or prototypes” and not the working ones.

In 1958, the year of his death, he spent a stay in overseas where he was forced to sign a contract to stop his work about implosion, and cede the rights of his work. He signed it to get back to Austria and 5 days after his return he died on 25<sup>th</sup> September. He was forced to leave all models and working documents behind in overseas.

2008 All the models have now been transported to Bad Ischl, Austria and can be seen. Mrs. Ingrid and Mr. Jörg Schauberger, the grandson and his wife, are the administrators of the assets of Victor and Walter Schauberger. Under [www.pks.or.at](http://www.pks.or.at) you will find the complete and original biography of both.

### 3. Understanding Schauberger with the Eyes of TRIZ

The wish is the father of the idea; this simple sentence contains enough information about what may become of an innovation/idea.

Schauberger had the wish/idea to create things and systems which follow nature, since nature is a permanent creator. Day and night and everywhere on our planet an uncountable flow of creation is going on and this energy has been flowing and creating for millions of years.

It depends on our energy whether we will succeed in getting connected to this energy in order to use it in our technical or other systems and it is never a question of time.

If we take the wish as a local quality in an innovation process, it would be the number 3 because this number represents the start and the goal at the same time.

### 4. Helixes/ Spiral/ Vortex

A hurricane/storm, seen as a Helix/Spiral/Vortex



**Figure 12**

It applies the following innovative principles

Principle 4. Asymmetry

Principle 5. Unification

Principle 14. the motion and part itself is round

Principle 15. it is more dynamic than the surrounding air

Principle 1. due to its dynamics it separates itself from the remaining air

Principle 16. higher amount of air on the surface than on ground

Principle 13. the wind blows vertically and not horizontally - this results in

Principle 8. suction

Principle 19. continuous action, seen from a distance its round movement looks like a asymmetric sinus curve becoming a space curve.

Principle 20. its continuous rotation in itself

Principle 33. homogeneity

Principle 36. phase change

Principle 37. thermal extension

It is a helix made of air and the movement of water.

A snake which swims in the water moves like a Helix but causes no harm to its surroundings - like a storm does, even though the main movements are the same.

This effect can be found in the case of shark skin, but the helixes are much smaller and yet strong enough to separate themselves from the remaining water so that a small but fast and powerful “atmosphere” is created around the shark skin. The water seems to be “another dimension” that generates power from the resistance, like in some Asian self-defence methods where the power of the attacker is used/transformed by the defender for his defence.

Principle 22. Harm is transformed into a benefit

If we find the right motion for a solution, the resistance can be used to stabilize and reinforce the motion using less energy.

Most motions which we produce with our technical systems are pushing and pumping, this means that we are producing more resistance or that we have to use a lot of energy for these motion processes.

The machines and the systems are complex and frequently have many moving parts, and may require a lot of maintenance.

In nature we do not find maintenance. The more maintenance a system requires, the more it represents an “unnatural movement”

Schauberger said “wrong movement contains the seed of death/destruction” .

## 5. Examples in nature and water



**Figure 13.**

On every tree or flower you will see a helix. If you take a look, a helix is always present.

The creation of our weather is effected with helixes.



**Figure 14. Typhoon**

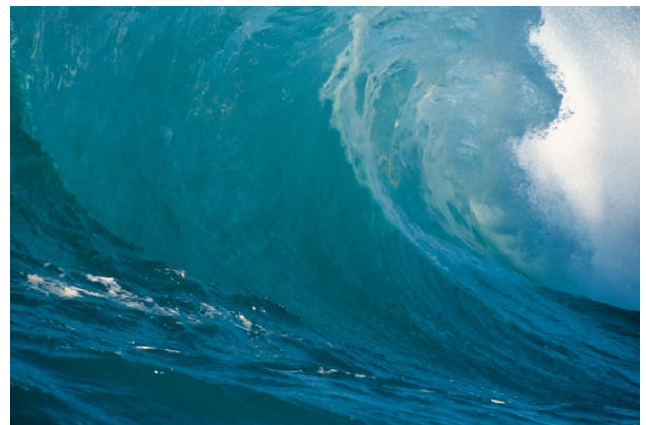

**Figure 15. Wave**

The natural motion of water is created with helixes



**Figure 16. Snake.**

Snakes use helixes for moving and saving energy

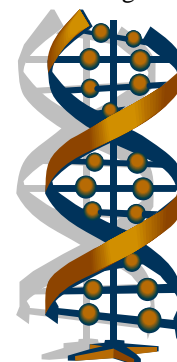

**Figure 17. DNA**

Our genetic building plan is saved in the form of helixes in our DNA.

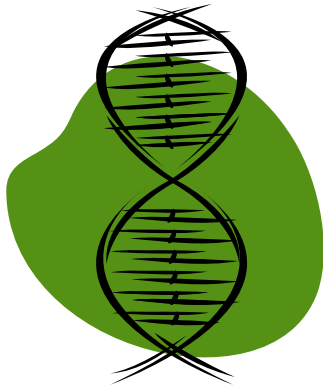

**Figure 18. Two fish**

It looks like two fish which pass each other. A helix can be seen in this way. The “fish” are not crashing into each other; they are passing by each other by screwing around in a helix form.

No notable harm is caused during this motion.

## 6. Motion and Treatment



**Figure 19. Helix Plow**

The form of this helix plough for agriculture which was created by Schauberger looks like shark skin. When he made this invention, the governmental and ecological experts warned that the use of this plough would result in an excess production which would reduce the prices for food and for this reason it was stopped.

Instead they promoted the use of N<sub>2</sub> (nitrogen/nitrate and chemicals).

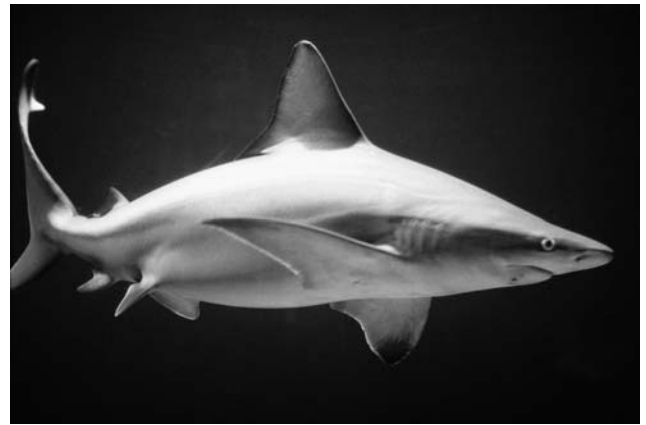

**Figure 20 . Shark**

The effect can be observed in our actual production of food. In Europe some vegetables may be treated 7-50 times with chemicals which we absorb via our food.

Adding to this is the chemical treatment during the food processing, as for example in the baking industry. This food contains only few nutrients and the quality is very low. (You feel tired after such a meal)

The ground/earth is contaminated with these chemicals and the useful and important micro- and macro-organisms are destroyed or severely damaged. Another effect is the sinking of the ground water level because the earth is no more able to absorb and store the rain water. This means that this system causes more flooding and erosions.(2)

The cause and its consequences may not be eliminated by this wrong treatment and the use of chemicals.

The only really positive thing about all this is that the situation might aggravate to a degree that the necessary change will be accepted and carried out. Principle 38. Strong oxidation can transform harm into a benefit, Principle 22. Even if the process takes a longer time.

### 6.1 Treatment of water

Schauberger studied water and its motion and flow in nearly untouched nature.

On the basis of these studies and observations he created helix pipes. He said that the water moves in a natural way in these pipes.



**Figure 21. Helix Pipe**

This is a view in such a pipe made of copper.

There is a significant contradiction in the movement in such a pipe (and also in rivers). On the one hand the distance the water covers is longer than in a regular pipe, but on the other hand the water is flowing stronger and faster in these pipes. Furthermore it is also able to transport goods which are heavier than its own weight.

Schauberger said that a pump should not produce suction by pressure, because the pressure cuts the “water fibre/thread” in pieces which means that its natural dynamics are destroyed.

In a normal pipe you will find sediments on the ground - regardless of its pressure you will always find sediments.

A Helix pipe is self-cleaning; the heavy goods are transported in the middle/centre where the flow is the most powerful, Principle 15. Its flow is more dynamic.

## 6.2 The trout engine & Shinkansen 700

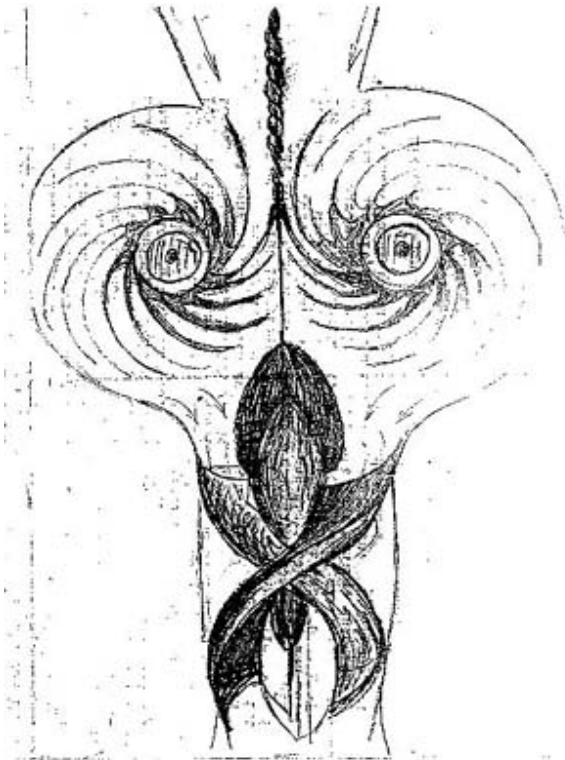

**Figure 22. Trout engine**

A figure from Schauberger,

Trout are able to stand in wild water and to escape against the stream. A trout can overcome waterfalls and move upwards in water which falls down. I could and cannot verify this fact, but at first glance it appears very likely that the Shinkansen 700 series uses this kind of effect in some way.



**Figure 23. Shinkansen Trains, wikimedia**

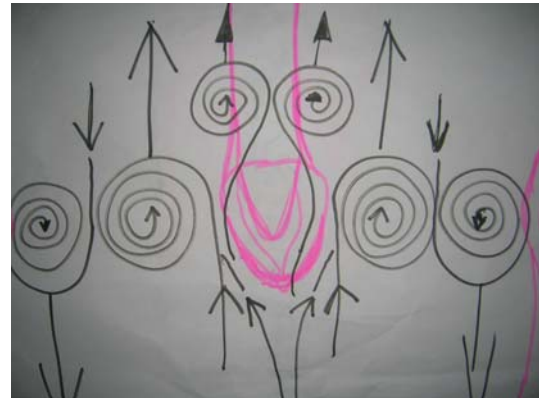

**Figure 24.**

This figure does not show the correct turning direction, it shows just that the train is surrounded by helixes/vortices. If two Trains meet the vibrations from turbulences are less than regular, the rolling/vortex motion creates only few turbulences because they are mainly absorbed by the motion of the helix/vortex.

## 6.3 Flowing Water in a River

If you watch a naturally flowing river, you can see Helixes/Vortexes on one shore, if you look at it for a longer time you will get the impression that the water is transporting itself like a belt conveyor and the helixes appear like little engines in this transport process.

On the other shore you will see the water moving in nearly all directions, I think this prevents the water from sucking on the shore.

## 7. Conclusion

Natural motion contains curves and is round like our planet. If these curves would be straight lines, the Earth would possibly be a line.

This paper gives only a brief picture about the work of Victor Schauberger. His son Walter continued his work just as his Grandson Jörg Schauberger does this in our time.

As you see, TRIZ can be used as tools for better understanding and within using it further the creations, solutions become more simple and effective.

The language of Schauberger is very specific and many people do not understand it in German so I hope this presentation is understandable.

Please notice that I am not a scientist, which means I do not calculate or know any physical or mathematical formulas. However, I can talk to you on the basis of TRIZ.

THANK YOU for your attention,

Especially I would like to thank Mr. Toru Nakagawa and the Japan TRIZ Society for giving me the possibility to be here.

If you have any questions, please feel free to ask me.

## Appendices:

**Side 1:\*** Water is even contained in a burning flame / **Elie Hien** conseiller des Shamanes France/Burkina Faso is a Spiritual Master and consults for example: Glendale and Stanford University(staff), Governments, the UN and people and institutions around the world.



**Fig.25 Elie Hien**

**Figure 1.-4.** ©Wolfgang Sallaberger

**Figure 5-11. 18,20,21.:** with permission from©implosion e.v. from <http://www.implosion-ev.de>

**Figures 6,7.:** A logging Flume / round bottom instead of angled, with applications in it to produce Helixes

**Figure 8.:** Home Power Plant: =helix +Fluid +motion=energy

Schauberger said the Fluid should reach sonic speed

**Figure 9,10,11.:**Repulsive =external start energy + motion + absorbing air/fluid + motion = creation of energy without heating

**Figure 18.:** Helix plow made from copper, tests at the university of Linz could document a average production of plus of 60% by using this plow.

**Figure 25.** Elie Hien from Homepage of Rita Martens : [www.ritamartens.de/Papa\\_Elie/papa\\_elie.htm](http://www.ritamartens.de/Papa_Elie/papa_elie.htm) !

**Figures:12,13,14,15,16,17,18,** taken from free clip arts under [www.office.microsoft.com](http://www.office.microsoft.com)  
ULR:<http://office.microsoft.com/de-de/clipart/FX101321031031.aspx?pid=CL100570201031>

**Figure 22.** taken from [www.tattva-viveka.de](http://www.tattva-viveka.de) under

**Figure 23** taken from wikimedia  
ULR[http://commons.wikimedia.org/wiki/Image:T%C5%8Dkaid%C5%8D\\_Shinkansen\\_700\\_&\\_300\\_001.JPG](http://commons.wikimedia.org/wiki/Image:T%C5%8Dkaid%C5%8D_Shinkansen_700_&_300_001.JPG)

**Figure 24** © Wolfgang Sallaberger



**Author: Wolfgang Sallaberger**

Born 1972 in Austria

9 Years of regular school

1987 to 1990: 3 years of traineeship as a cook, concluded by an exam

10 years of practice in 13 different restaurants and hotels

1994: first job as an executive chef

1997: continuation and management of the family restaurant including a complete renovation until 2008

1998 first contact with Elie Hien, my “spiritual father”

Until now learning from him, would like to be like that not too much, not too less, having everything and nothing.

2004: first protected right for a method for the production of convenience vegetable bouquets

2004 – 2005: education as an innovation manager, first contact with TRIZ

2006: first presentation at the Austrian TRIZ Congress in Leoben, membership in the Austrian TRIZ Society

2007: co-author of the book “TRIZ Appliance and further development in non-technical fields” edited by Dr. Petra Rietsch at Fachultas publishing company, original title in German: TRIZ Anwendung und Weiterentwicklung in nicht technischen Bereichen ISBN 978-3-7089-0147-3

Presentation at the ETRIA Conference, TRIZ Future 07 in Frankfurt am Main/Germany, presentation available as “TRIZ Current Scientific and Industrial Reality” edited by Carsten Gundlach and Udo Lindemann and Horst Ried ISBN978-3-89958-340-3

2008 start of a project for a Prototype for new food creations.

2008 leaving Austria

**Contact :**

Wolfgang Sallaberger

Groszsteingrub 8, 4731 Prambachkirchen, Austria

Please note that I will move. This address will change in 2008, but the e-mail address will stay the same.

Email: [w.sallaberger@congado.at](mailto:w.sallaberger@congado.at)

Phone:+4369911227913