

The Fifth TRIZ Symposium in Japan, 2009
Held by the Japan TRIZ Society, NPO

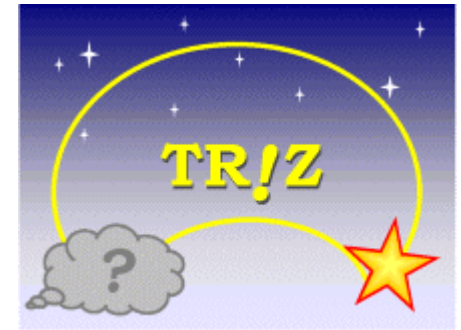

**How to Prevent Cords and Cables
from Getting Entangled:
A Study of Systematic Classification of Various Solutions**

**Toru Nakagawa, Tomoyuki Itoh, and Masanobu Tsukamoto
(Osaka Gakuin University)**

September 10-12, 2009

**National Women's Education Center, Japan (NWEC)
(Ranzan-machi, Hiki-gun, Saitama Prefecture, Japan)**

Outline of Our Talk

- Thesis works by T. Itoh (2007) and M. Tsukamoto (2009)
- 'Cords/cables get messy and entangled around PC, around TV, etc.'
 - I want to find good solutions (T. Itoh)
- This problem is seen everywhere since many many years.
 - ==> Not to try to find individual solutions,
 - But rather to collect solution ideas and systematize them.
- Collection of various solutions
- Classify them in a bottom-up manner
- Examine the solutions by extending the scope of analysis:
 - A single cord/cable --> Multiple cords/cables --> Connection parts
 - > Whole system of multiple devices and cords/cables
- Have obtained a hierarchical system of solution ideas

Thesis work in Nakagawa's Seminar Class

Main Theme: Creative Thinking in Problem Solving

Try to solve familiar problems creatively with the use of TRIZ/USIT.

Thesis work on individual topic but with group discussion

T. Itoh: "I want to prevent cords/cables from getting entangled around PC."



**==> Since this is a so widely spread problem,
we should better collect many solution ideas around us
and try to systematize them.**

Strategy (1) Let's go out to various places and observe and survey as many solution examples as possible.

Fields of observation:

Fields of Problems & Solutions **Fields of Solution Devices**

At home (living room, study, kitchen)

Offices,

Laboratories

In the factories,

Inside the devices, rack housing, ...

**Electric, PC shops,
Do-it-yourself stores,**

Web sites, ...

Strategy (2) Observe the individual solutions closely and understand the mechanisms, features, etc.

Ex. 1 A mouse with a cord reel

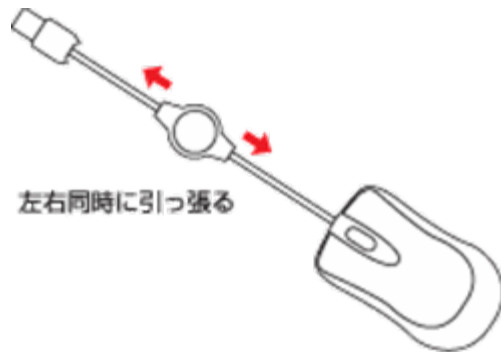
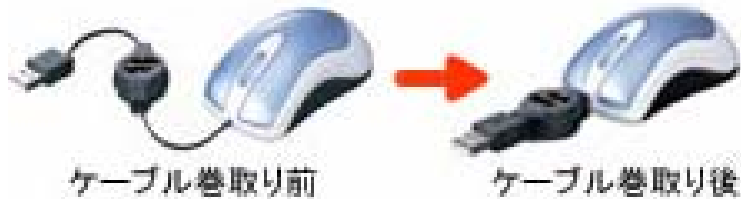

Winding up the cord:
The cord can be stored in the reel case,
the cord length is adjustable in 5 ways.

Ex. 2 A soft plastic case for winding up the cord.



Winding up the cord:
Open the soft cover,
wind the cord around the body,
and close the cover while using.

Strategy (3) Focus on the functions, classify the solution ideas in a bottom-up way, and find a system of solutions

"How to prevent cords/cables from getting entangled" Tomoyuki Itoh (Jan. 2007)

1. Eliminate the properties of getting entangled easily

- flexible but not bent locally
- without remaining twisted

2. Make the cords/cables adjustable in length

- Extending and shrinking for itself
in nesting, like a rubber, in a spiral, like an accordian, ...
- Using longer and shorter cords/cables interchangeably on request
- Connect shorter ones for a longer use; disconnect for a shorter use
with connectors at the both ends for easy to connect/disconnect

3. Winding up the cords/cables

- winding up into a reel carton,
- winding up manually, with a spring, automatically, ...
- winding up around something

"How to prevent cords/cables from getting entangled" (2)

4. Fold up and keep

5. Connect in the modular manner

- Connect unit modules
- Multi-branching

6. Use different/variable shapes

- Straight type and bent type
- Flexible/variable type (bending, rotatable, extendible, ..)

7. Bundle and bind

- with twisting, tying, hooking, buttons, adhesive, ...
- with holding elastically,
- with elastic spiral plastic, with winding tape, ...

8. Combine and unite

- Combine multiple cords/cables and unite into a single cord/cable
- by braiding, by winding a cord/cable around others,
- by putting multiple cords/cables in a protector (or a framing)

"How to prevent cords/cables from getting entangled" (3)

9. Set the devices at fixed positions and fix the cords/cables

- Set multiple devices in a rack housing and fix the cords/cables
- Make the system maintenance-free

10. Rearrange cords and cables

11. Hide the cords and cables in unseen places

- under the floor, over the ceiling board,
- under the desk, behind the desk, inside a box,
- inside a chassis

12. Eliminate cords and cables

- Use wireless communication
- Embedding cords/cables inside the devices
- Combine/unite two devices to eliminate the cords/cables
- Use batteries (power supply without cords)

12 categories at the top level of hierarchy

==> Needs more systematic thinking/scheme

We need to reconsider the problem. ← **TRIZ/USIT Thinking**

"We want to solve the problems where cords/cables get messy and entangled"

What is the problem, unwanted effects? ← **USIT Process**

- Confusing in the connection relations among the devices
- Difficult for managing and maintenance
- Using un-necessarily long cords/cables
- In the risk of causing electric leakage and burning
- Occupying un-necessary spaces, blocking other use
- Looks messy, untidy, ...

What are the plausible root causes?

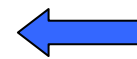

USIT process

- Many devices involved.
- Need many cords/cables.
- Necessary to remove, add, and replace the devices from time to time.
- Necessary to move the devices from time to time.
- A variety of devices and different sorts of cords/cables.
- Possible future change in the system.
- Cords/cables must not be disconnected.
- Cords/cables are longer than they are needed.
- Cords/cables gather at some places.
- Cords/cables get entangled in a complex way.

Problem Situation (a sketch)

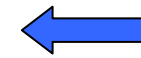

USIT process

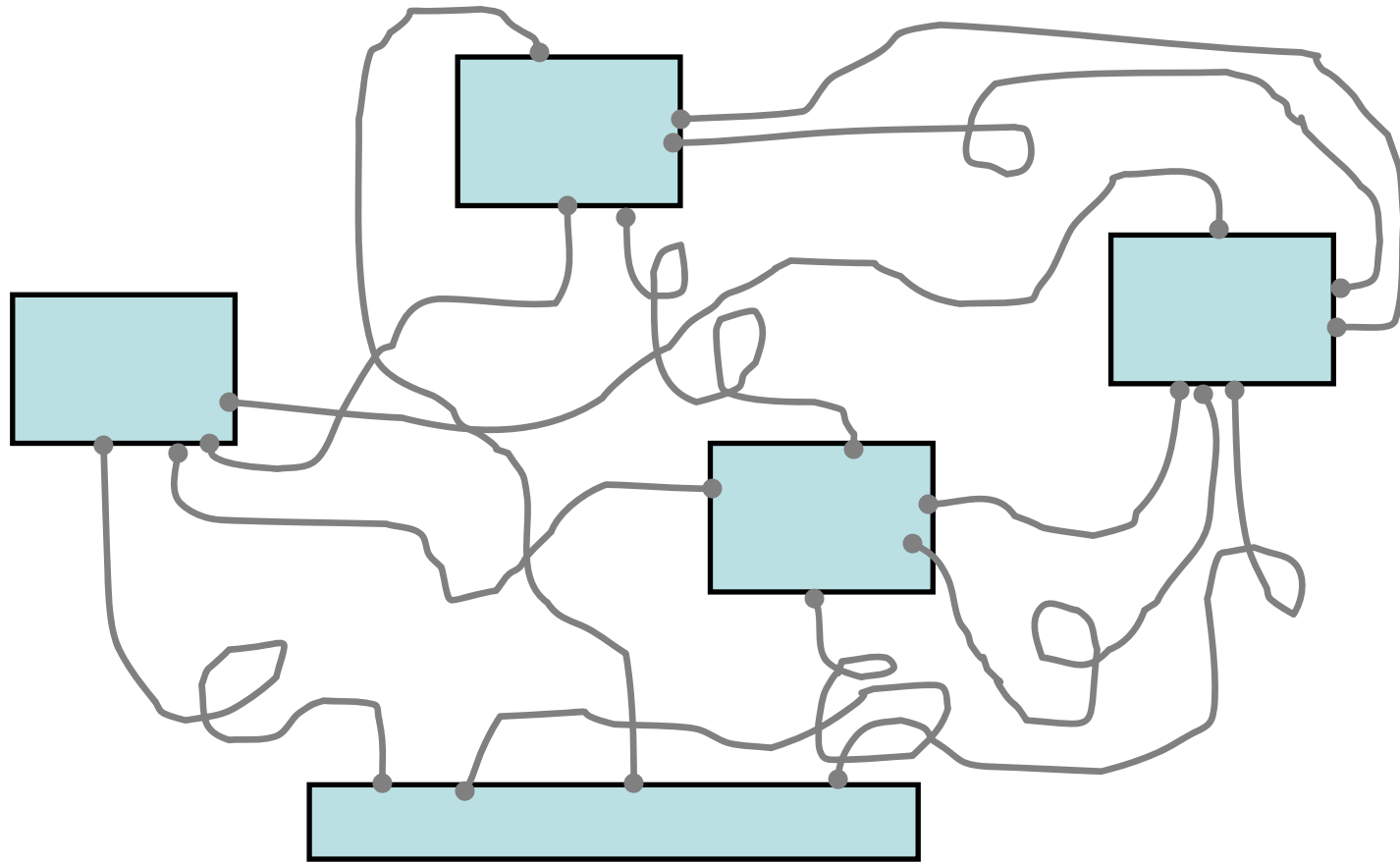

Strategy: To extend the scope of the target system from simple to complex step by step

Scope A. A single cord/cable

Problem situation

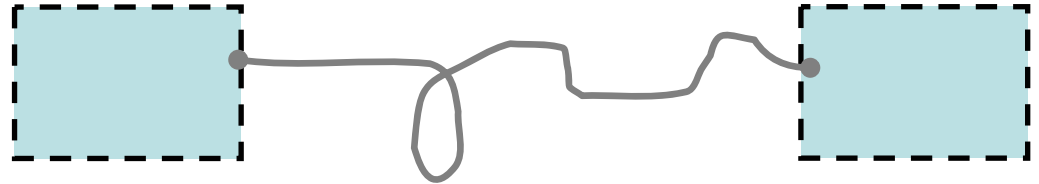

**Solution directions:
To adjust the length
so as not to get entangled**

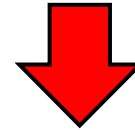

Extend and shrink



Wind it up



Fold t it up



**Eliminate the property of
getting entangled easily**



Scope B. Multiple cords/cables

Problem situation

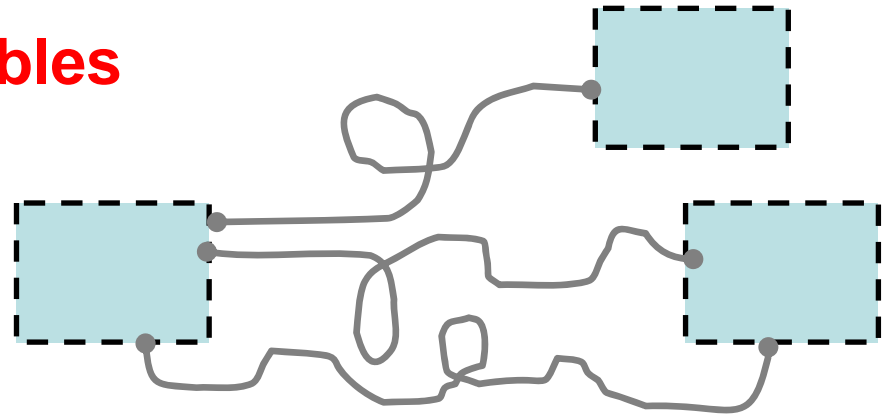

Solution directions:
To bundle, combine, and unite
multiple cords/cables

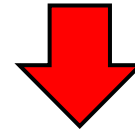

To bundle

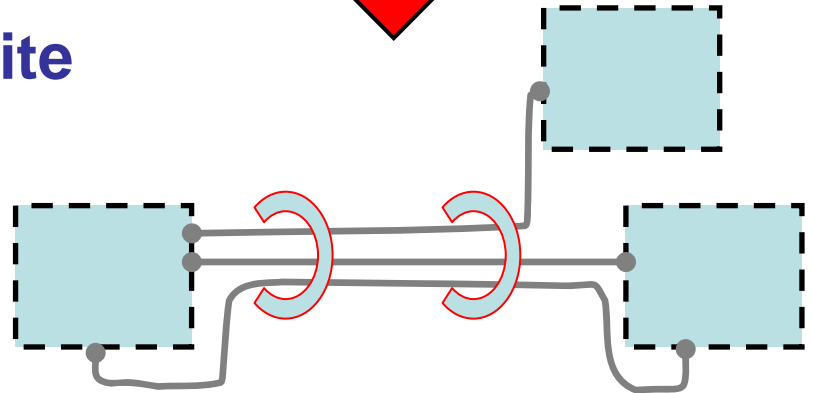

To combine,
To unite

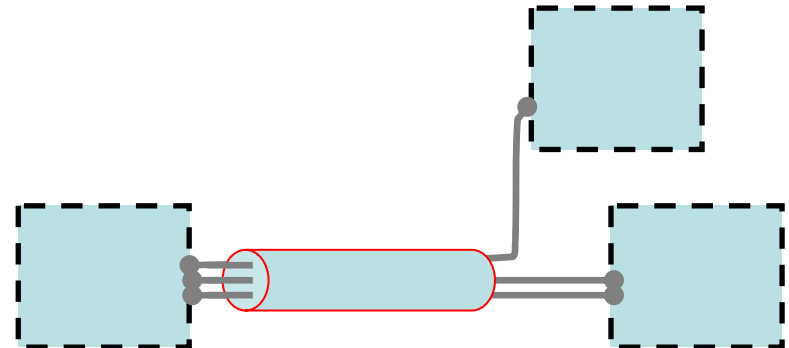

Scope C. Connection parts between devices and cords/cables

Problem situation:

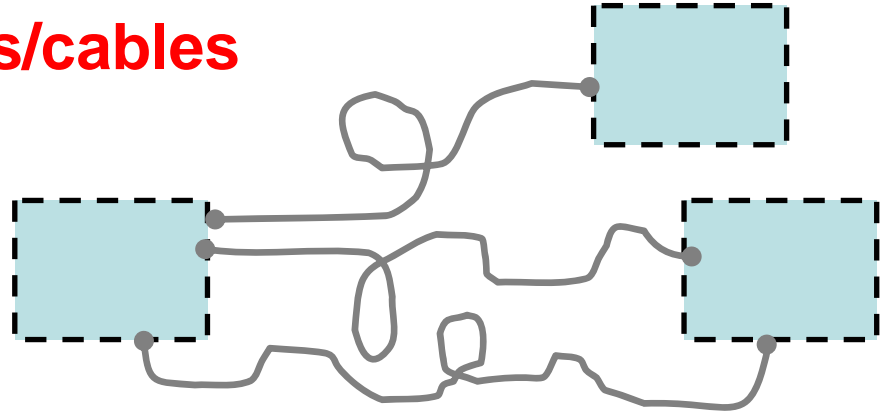

Solution directions:
To standardize the connection parts,
for easy connection/disconnection

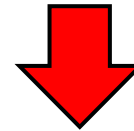

To use standard connectors
for easy connection/
disconnection

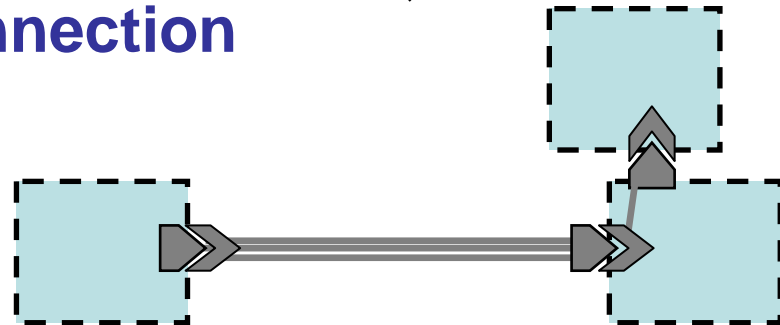

Use connection modules

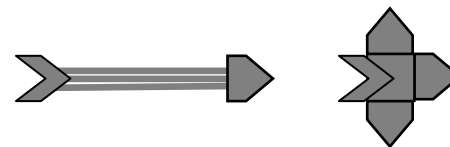

Scope D: A system composed of multiple devices and multiple cords/cables

Problem situation

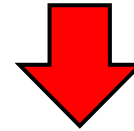
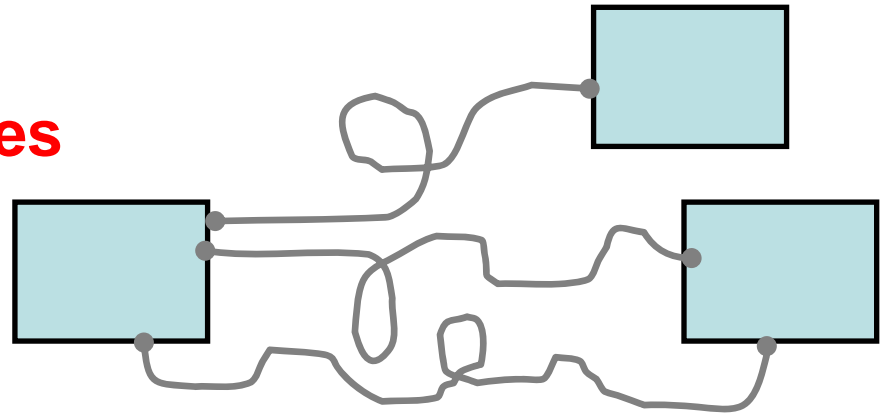

**Solution directions:
Reorganize the whole system,
Eliminate or hide cords/cables**

**Reorganize the system,
for merging, dividing, ...**

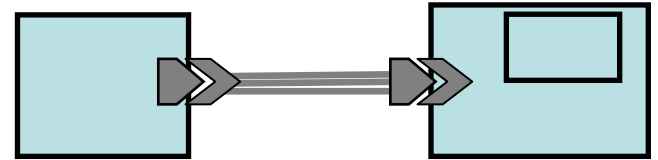

Eliminate cords/cables

Hide cords/cables

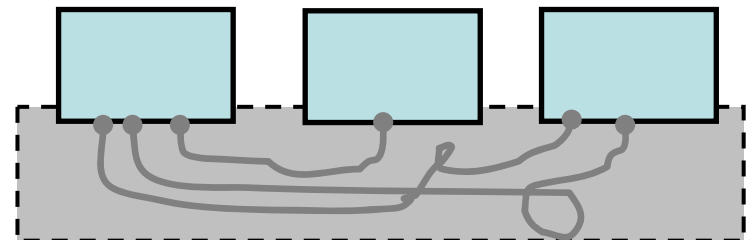

A System of Solutions for Preventing Cords/Cables from Getting Entangled

(Jul. 2009)

A. A single cord/cable: To adjust the length

- A1. To expand and shrink
- A2. To wind up
- A3. To fold up
- A4. To eliminate the property of cord/cable being easy to get entangled

B. Multiple cords/cables: To bundle, to combine, and to unite,

- B1. To bundle at a place
- B2. To bundle along a certain distance
- B3. To combine into a single united cord/cable

C. Connection parts between devices and cords/cables:

To use standardized connectors and connection modules

- C1. To use standardized connectors for easier connection/disconnection
- C2. To use connecting modules having some additional functions
- C3. To use different shapes and spatial arrangements

D. A system of multiple devices and multiple cords/cables:

To examine the devices and to store cords/cables in or around the system

- D1. To examine for merging, uniting, dividing, taking out, etc. of the devices
- D2. To reorganize the arrangements of devices and cords/cables
- D3. To fix the cords/cables at their places
- D4. To eliminate the cords/cables
- D5. To hide the cords/cables at some appropriate places

A. A single cord/cable:

To adjust the length and prevent from getting entangled

A1. To expand and shrink for adjusting the length

like a telescope,

like a rubber,

like a spiral telephone cord

A2. To wind up for adjusting the length

in a spiral,

in a winding-up carton,

around something,

in the form of character 8

A3. To fold up for adjusting the length

folding and binding,

in an accordion style

A4. To eliminate the property of cord/cable being easy to get entangled

no local bending,

no twisting

(with some mechanism for eliminating the twist)

**B. Multiple cords/cables:
To bundle, to combine, and to unite,**

B1. To bundle multiple cords/cables at a place

The bundle held with twisting,

with tying,

with hooking,

with fixing in a hole,

with adhesion,

within a frame,

The bundle held with elastic closure,

with an elastic spiral belt,

with a winding tape

How to Prevent Cords/Cables from Getting Entangled (4)

B2. To bundle multiple cords/cables along a certain distance

Within a frame,

with an elastic spiral belt,

with a winding tape

B3. To combine multiple cords/cables into a single united cord/cable

By braiding,

by winding each other,

by attaching side by side,

-- a power cable

-- about 30 signal lines in a belt

By forming a new united cord/cable,

such as a composite cable,

a multiplex cable

-- a telephone cable

-- an Ethernet cable

-- a USB cable

-- a multiplex fiber optics cable

C. Connection parts between devices and cords/cables:

To use standardized connectors and connection modules

C1. To use standardized connection parts between devices and cords/cables for easier connection/disconnection

At the connection parts of the devices

-- Modular jack for telephone line

At the ends of cords and cables

Direct connection at one end, while a connector at the other end

Connectors at the both ends

- **Use longer and shorter cords/cables interchangeably on request**

-- 1 m, 2m, 3m cords

- **Connect shorter cords/cables to extend,
and disconnect them for shorter use**

-- Extension cord

C2. To use modules specialized for connecting function and containing some additional functions

- Additional with on/off,
- with route switching,
- with multiple branching,
- with an adaptor,
- with a filter,
- with twist elimination

C3. To use different shapes and spatial arrangements in the connection parts and the connection modules

- With vertical or horizontal shape,
- with straight or bent shape,
- with flexible/variable shape

D. A system of multiple devices and multiple cords/cables:

To examine the devices in their functions, structures, schemes and to store cords/cables in or around the system

D1. To examine the functions and structures and to consider merging, uniting, dividing, taking out, etc. of the devices

Uniting into a new device (e.g. multiplex communication)

D2. To reorganize and optimize the arrangements of devices and cords/cables

Organize the devices as a unit set with reduced needs of change

Rearrange the cords/cables in the system

Decide the places to store movable devices and parts

D3. To reorganize the arrangements and
fix the cords/cables at their places

By reorganizing according to their paths,
by setting the devices and paths in the 3D space

By fixing inside the devices,

in the system,

in the environment

(desk, floor, wall, ceiling, etc.)

D4. To eliminate the cords/cables

- By embedding the cords/cables in the base,
- by combining multiple devices into one,
- by using batteries

- By using wireless communication between the devices

D5. To hide the complex cords/cables at some appropriate places

- Inside the chassis,

- in a box,

- under or behind the desk,

- over the head

- Under the (free-access) floor,

- over the ceiling board,

- inside the ducts,

- inside the piping trench

Discussions

(1) Significance of systematic classification

Able to understand the directions of evolution systematically

--> Able to understand the essence of new products

--> Capable to create our own solutions to our problems

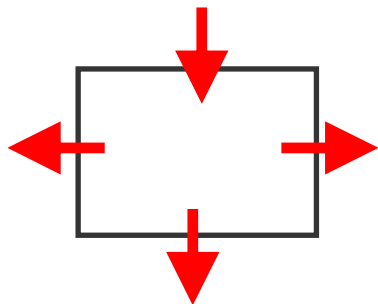

**Model of
Multi-branching**

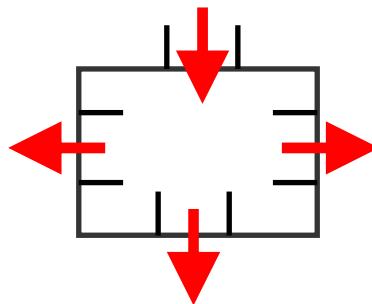

**Multi-branching
power source**

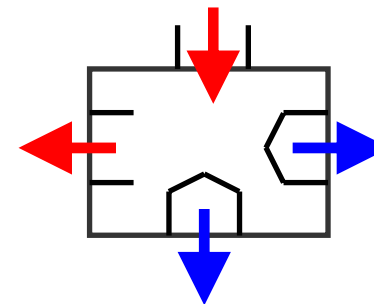

**Multi-branching
power source variant**

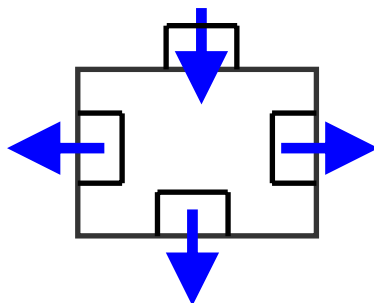

USB hub

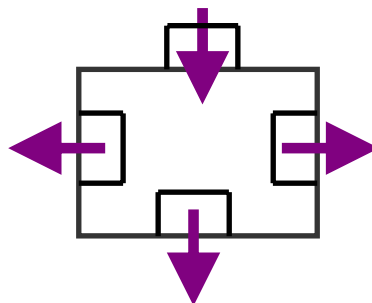

Ethernet hub

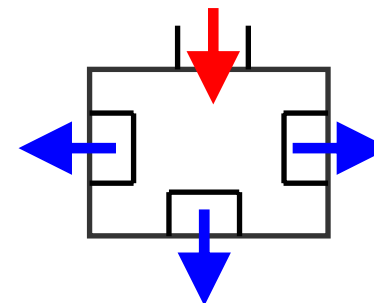

**Multi-branching
adapter**

(2) What are the Root Causes of this problem?

The basic ideas in our results, "A system of solutions for preventing cords/cables from getting entangled" are rather well known, and a variety of products for these solutions are sold commonly.

Nevertheless, the problem situations exist everywhere. --- Why?

E.g. Typical solution: Use short (but sufficiently long) power cord, and extend it when necessary (C1, C2).

Requirements on connectors:

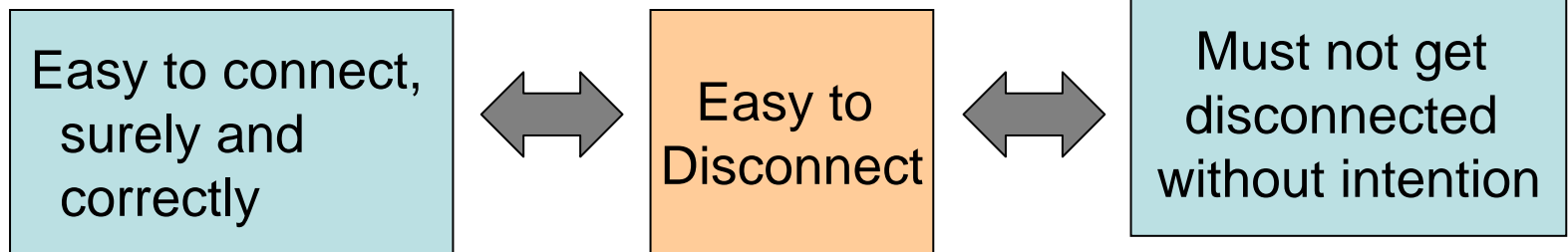

Commercial products contain a lot of improvement, but still have some defects/insufficiencies in fulfilling the requirements.

--> Common sense: Should not use connectors in the middle of cords unless absolutely necessary.

Power cords of most devices are 2 - 3 m long. (in sales)

In most cases, ordinary use requires 1- 2 m of power cords.

==> Thus, 1 - 2 m of power cords are slack (extra length).

==> This causes the cords get entangled.

"We need the slack": when we give the device maintenance,
when we rearrange the devices,
when the power source is far than usual,
when we use it at other places,
when we think of different situations of many customers, ...

If we use a shorter cord usually, we sometimes need an extension cord.
But we can not have a guarantee that an extension cord is available.

After all, people have chosen to use the cords/cables longer than the usually-sufficient length, for the consideration of future possibility of needs. Such choices result in the extraneous lengths, which provide the root causes of many cords/cables getting entangled everywhere.

(3) Usage of TRIZ/USIT way of thinking

- Collecting many solution examples --> extracting essence of them
--> systematizing the solution principles.
 <-- fundamental approach in TRIZ.
- What is the problem? What are the root causes?
 <-- TRIZ / USIT.
- Abstract thinking with emphasis on the functions.
 <-- TRIZ / USIT.
- The scope of system analysis is extended step by step:
 A single cord/cable --> Multiple cords/cables
 --> Connection parts --> The system (and environment)
 <-- system's thinking in TRIZ / USIT.
- Solution ideas are backed up by Inventive Principles
 <-- TRIZ.
- Considerations on attributes of solution items
 <-- TRIZ / USIT.